

ReVent®

Ventilation Fans

150 CFM

ReVent Ventilation Fan

Model - RVS150

Performance - High airflow 150 CFM, low sound 1.3 sone



ReVent with LED Lighting

Model - RVL150

Performance - High airflow 150 CFM, low sound 1.2 sone

LED - Adjustable 2700/3000/3500 /4000/5000K, 1000L, dimmable



ReVent with Humidity Sensing

Model - RVSH150

Performance - High airflow 150 CFM, low sound 1.3 sone

Humidity - Automatically turns fan on when moisture is present and off when dry

Min/Hour Timer - Can be set 0-60 minutes, runs fan for set time every hour



ReVent with LED Lighting and Humidity Sensing

Model - RVLH150

Performance - High airflow 150 CFM, low sound 1.2 sone

LED - Adjustable 2700/3000/3500 /4000/5000K, 1000L, dimmable

Humidity - Automatically turns fan on when moisture is present and off when dry

Min/Hour Timer - Can be set 0-60 minutes, runs fan for set time every hour



| SPECIFICATIONS | Models | RVS150, RVL150, RVSH150, RVLH150 |
|----------------|----------------------|--|
| | Exhaust Diameter | 6 in (15.24 cm) |
| | Voltage (volts) | 120V |
| | Frequency (hertz) | 60Hz |
| | Power (watts) | 37.5W |
| | Air Flow at 0.1 CW | 150 CFM |
| | Noise (sones) | 1.3 Sone (non-lighting), 1.2 Sone (lighting) |
| | Shield Size | 13 3/8" x 13 3/8" in (34 x 34 cm) |
| | Opening Length | 10 1/2" in (26.7 cm) |
| | Opening Width | 10 1/2" in (26.7 cm) |
| | Housing Length | 10 1/2" in (26.7 cm) |
| Housing Width | 10 1/2" in (26.7 cm) | |
| Housing Depth | 6 3/4" in (17.1 cm) | |

| LIGHTING MODELS | |
|---------------------|----------------------------------|
| Models | RVL150, RVLH150 |
| Brightness (lumens) | 1000L at 4000K |
| Color Temp (kelvin) | 2700, 3000, 3500, 4000, or 5000K |
| Power (watts) | 13W |

performance at 6" ducting

| Static Pressure (in wg) | Airflow (cfm) | Sound (sones) | Energy (watts) | Duct Size |
|-------------------------|---------------|---------------|----------------|-----------|
| RVS150, RVSH150 | | | | |
| 0.1 | 150 | 1.3 | 37.5 | 6 in |
| 0.25 | 116 | | 36.7 | 6 in |
| RVL150, RVLH150 | | | | |
| 0.1 | 150 | 1.2 | 37.5 | 6 in |
| 0.25 | 111 | | 36.7 | 6 in |

Product of GTR Technologies Inc. All rights reserved.
USA and International Patents and Patents Pending
See Patents at www.ReVentfans.com

1-360-876-2974
1420 Lumsden Road
Port Orchard, WA 98367

May be used to comply with



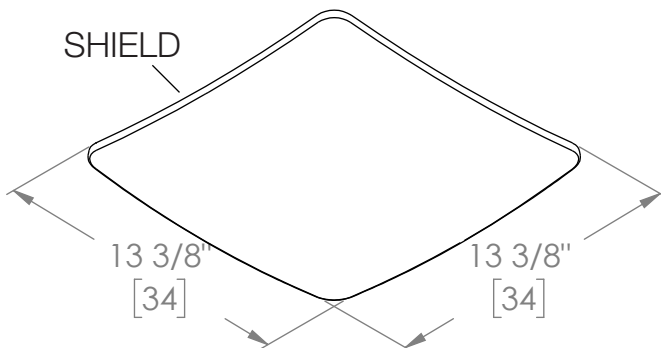
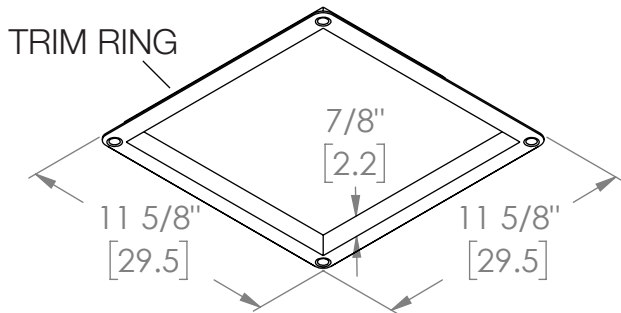
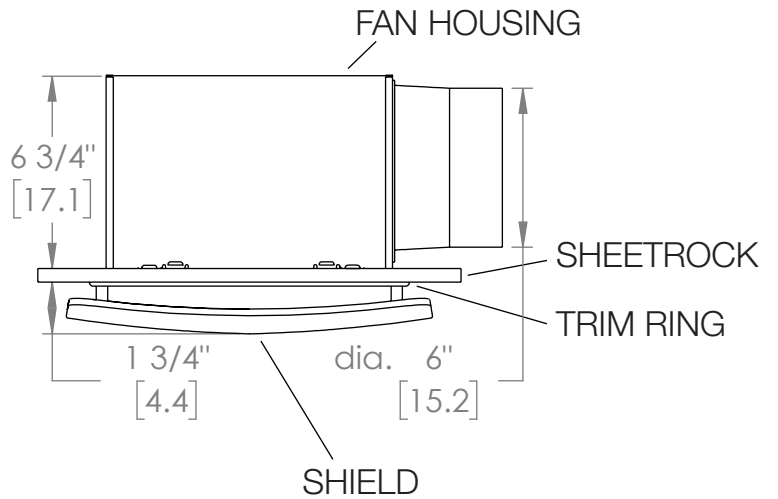
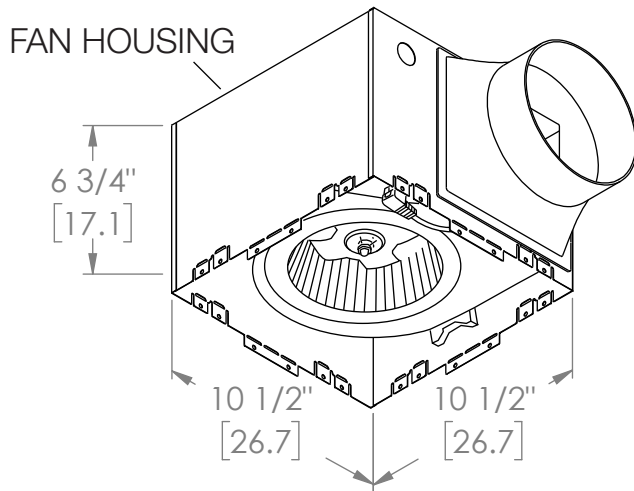
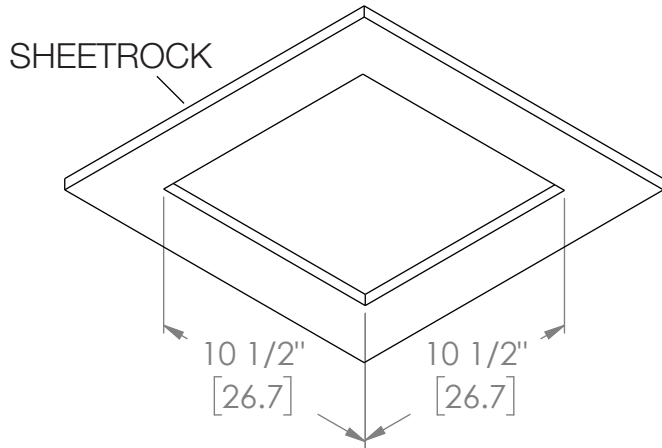

ReVent®
Ventilation Fans

THIS DRAWING IS THE PROPERTY OF GTR TECHNOLOGY INC. AND TRANSMITTED IN CONFIDENCE. THE REPRODUCTION, USE, OR DISCLOSURE, IN WHOLE OR IN PART, OF THE DESIGN AND DETAILS CONTAINED HEREIN IS PROHIBITED WITHOUT THE WRITTEN PERMISSION OF GTR TECHNOLOGY INC.

PART #
**RVS150, RVL150,
RVSH150, RVLH150**